



TECHNICAL DATA

KR 6 ARC



WORKING IDEAS



KR 6 arc

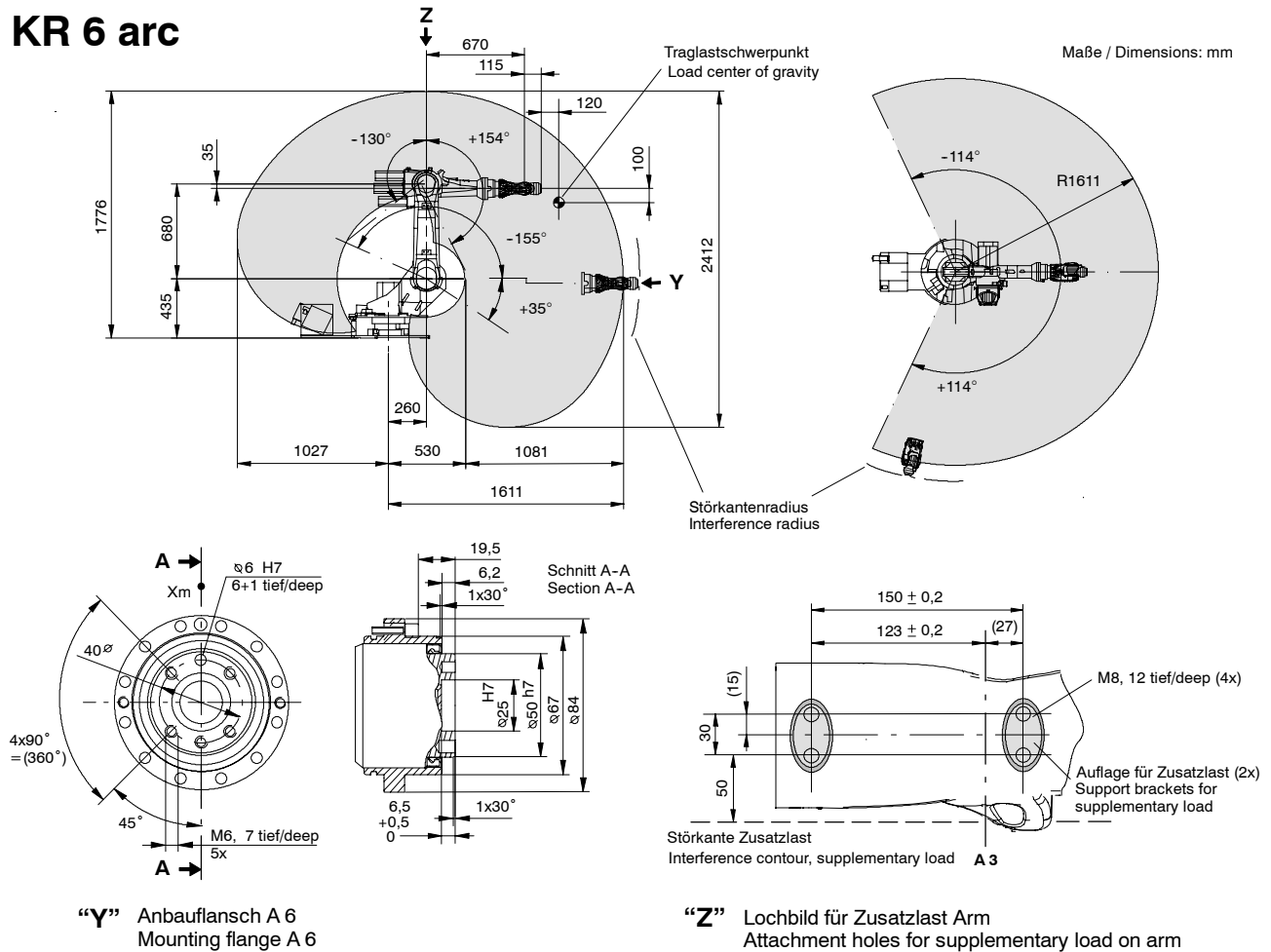

Traglast / Payload:	6 kg	
Zusatzlast Arm / Schwinge / Karussell Supplementary load on arm / link arm / rotating column:	10 kg / variabel/variable / 20 kg	
Max. Gesamtlast / Total distributed load:	36 kg	
Anzahl der Achsen / Number of axes:	6	
Handvariante / Wrist variant:	Zentralhand 6 kg / In-line wrist 6 kg	
Anbauflansch A 6 / Mounting flange A 6:	DIN ISO 9409-1-A40	
Einbaulage / Mounting position:	Boden, Decke / Floor, ceiling	
Wiederholgenauigkeit / Repeatability:	± 0,1 mm	
Steuerung / Controller:	KR C2	
Gewicht (ohne Steuerung) ca. / Weight (excl. controller) approx.:	235 kg	
Arbeitsraumvolumen / Work envelope volume:	9,2 m ³ ¹⁾	
Achsdaten / Axis data:	Bereich (Software) / Range (software)	Geschwindigkeit / Speed
Achse / Axis 1 (A 1)	± 114°	156°/s
Achse / Axis 2 (A 2)	+ 35° /- 155°	156°/s
Achse / Axis 3 (A 3)	+ 154° /- 130°	156°/s
Achse / Axis 4 (A 4)	± 350°	343°/s
Achse / Axis 5 (A 5)	± 130°	365°/s
Achse / Axis 6 (A 6)	± 350°	662°/s

1) Bezogen auf Schnittpunkt Achse 4/5. / Referred to intersection of axes 4 and 5.

- Antriebssystem elektro-mech. mit burstenlosen AC-Servomotoren. / Drive system electromechanical, with brushless AC servomotors.
- Wegmeßsystem digital-absolut. / Position sensing system digital-absolute.